



# DPI-24 differential pressure switch

USER GUIDE



# Contents

<b>1 Introduction.....</b>	<b>3</b>
1.1 About this user guide.....	3
1.2 Intended use.....	3
<b>2 Safety precautions.....</b>	<b>4</b>
<b>3 Main components.....</b>	<b>5</b>
<b>4 Commissioning.....</b>	<b>6</b>
4.1 Mounting the product.....	6
4.2 Connecting the pressure measurement hoses.....	7
4.3 Wiring.....	7
4.4 Configuring settings via device menu.....	8
4.4.1 Pressure measurement settings.....	10
4.4.2 Flow measurement settings.....	11
4.4.3 Output scale menu.....	13
4.4.4 Resp. time menu.....	14
4.4.5 Relay output settings.....	14
4.4.6 Span adjust menu.....	15
4.4.7 Span factory settings menu.....	15
4.4.8 The Exit menu view.....	16
4.5 Configuring settings using MyTool® application.....	16
4.5.1 Configuring measurement settings.....	18
4.5.2 Configuring communication settings.....	20
4.5.3 Saving and loading the configuration.....	21
4.5.4 Resetting device settings to defaults.....	22
<b>5 Maintenance.....</b>	<b>23</b>
5.1 Automatic zeroing.....	23
5.2 Manual zeroing.....	23
<b>6 Disposal.....</b>	<b>24</b>

# 1 Introduction

The DPI-24 differential pressure switch is a differential pressure indicator that combines the advantages of an electronic differential pressure switch for air (on-off relay) and a multi-functional differential pressure transmitter. It also includes a flow switch.

The DPI-24 differential pressure switch has one measurement output and one or two relay outputs. You can select the measurement range and the output mode during commissioning.

The optional display (-D models) shows pressure or flow measurement value and the relay status.

The models with the -2R option have two relay outputs for switching relays on and off.

The models with the -AZ option include an automatic zeroing function that automatically calibrates the zero point every 10 minutes.

You can configure the device settings via the device menu or using the MyTool Connect dongle and the MyTool® smartphone application.

## 1.1 About this user guide

This user guide contains important information about the installation, wiring, configuration and use of the product. Read this guide carefully before you install the product, connect the wires, or operate the product. Make sure that you fully understand all instructions before you start work. If you are not sure what the instructions mean, contact the seller or the manufacturer.

Follow all instructions in this user guide carefully. Always obey the applicable local rules and regulations.

The original instructions were written in English. If there are differences between the English instructions and the translations, refer to the English instructions.

If you find a mistake in the English instructions or in the translations, please send the details to the manufacturer.

## 1.2 Intended use

The DPI-24 differential pressure switches are intended to be used in commercial environments to:

- measure differential pressure or air flow in environments that have low operating pressures
- control the relays

These devices are compatible with dry air. They are intended to be connected to building automation systems in the HVAC/R industry.

## 2 Safety precautions

The product is developed, manufactured and tested according to high quality standards. However, instructions for safe use must be followed when installing, using or disposing the product or parts of product.

Read this user guide carefully before you commission, use or service this device. To avoid any kind of damage to people or property, follow the instructions carefully. Produal is not liable for any hazards, injury to people, or damage to property caused by incorrect installation or misuse of the device.

To avoid electrical shock or damage to equipment, disconnect power before you install or service the product. Use only proper wiring that is rated for the full operating voltage and maximum current in the system. The wiring must also withstand fault conditions.





To avoid fire and/or explosion, do not use the product in potentially flammable or explosive atmosphere.

Make sure that the product is not damaged before installation. Do not drop the product or use excessive force during installation. Do not use the product if you can see any damages.

After installation, the product will be part of a system whose specifications and performance characteristics are not designed or controlled by Produal. Refer to national and local authorities to ensure that the installation is functional and safe.

The product should only be used in professionally designed applications. Unauthorised modifications are not allowed. The product must not be used in relation with any equipment that in case of a failure may threaten, directly or indirectly, human health or life or result in danger to human beings, animals or property.

In this document, there are different warnings and notes. The warning and note types are defined in the following table.

Sign	Description
 <b>WARNING:</b>	The warning symbol indicates a potentially hazardous situation which, if not avoided, could result in death or serious injury.
 <b>CAUTION:</b>	The caution symbol indicates a potentially hazardous situation which, if not avoided, could result in minor or moderate injury.
 <b>Important:</b>	The important symbol indicates a potentially hazardous situation which, if not avoided, could result in damage to the device or property.
 <b>Note:</b>	The note symbol indicates a useful tip or a recommended way to complete a task. These notes also provide information that is useful but not critical to the user.

### 3 Main components

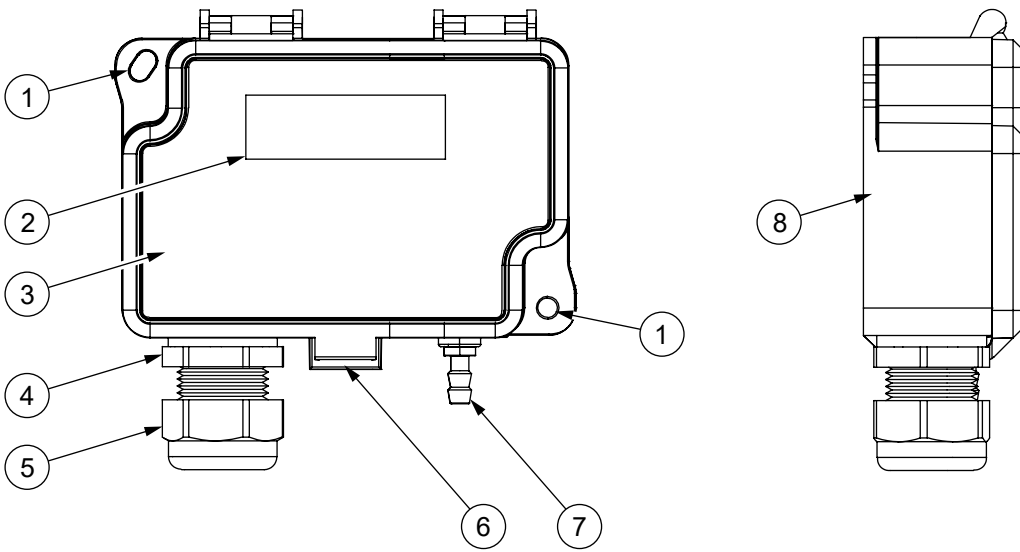

1	Mounting point	2	Display (-D models)
3	Cover	4	Cable gland
5	Strain relief	6	Cover latch
7	Pressure connection (+ high pressure / - low pressure)	8	Housing

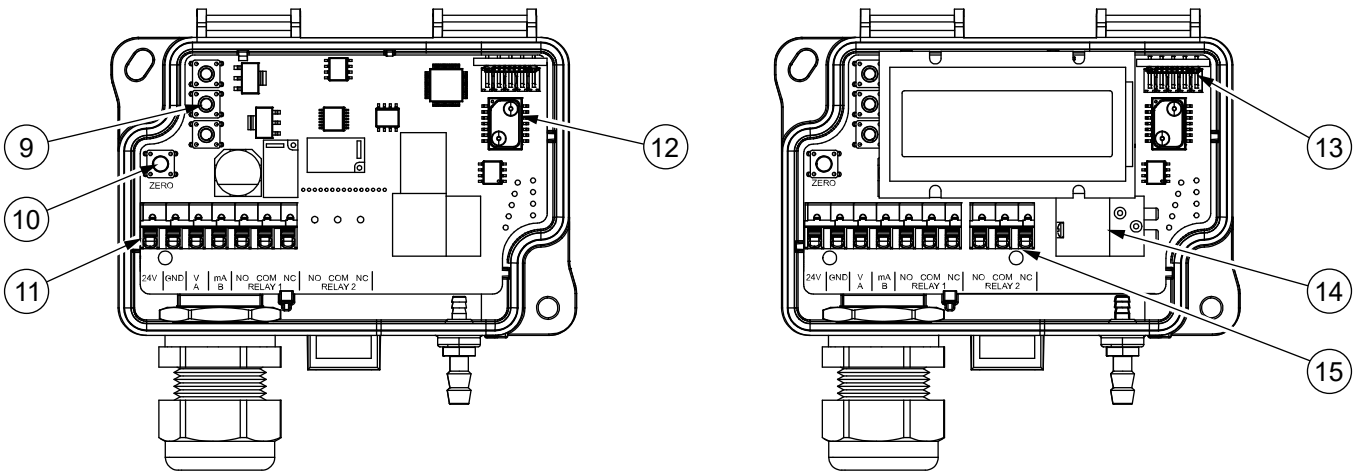

9	Buttons for the device menu	10	Zeroing button
11	Terminal block	12	Pressure sensor
13	Connector for MyTool Connect dongle	14	Automatic zeroing module (-AZ models)
15	Terminal block for the second relay output (-2R models)		

## 4 Commissioning

### 4.1 Mounting the product

**WARNING:** Handle the product with care. Dropping the product may cause internal damage and unwanted functions in the connected system.

**CAUTION:** Place the product outside the reach of children and animals.

**Important:** The product may only be installed in a location where the ambient conditions meet the operating condition requirements.

#### Operating conditions

Ambient temperature	-10...50 °C
Ambient temperature (-AZ models)	-5...50 °C
Ambient humidity	0...95 %rH (non-condensing)

1. Check that the product is not damaged during transportation.
2. Select the mounting position on a duct, wall or panel.
3. Use the device as a template and mark the screw holes on the mounting surface.
4. Select the mounting screws according to the mounting surface. The maximum screw diameter is 4.3 mm.
5. Make sure that the cable gland points down.

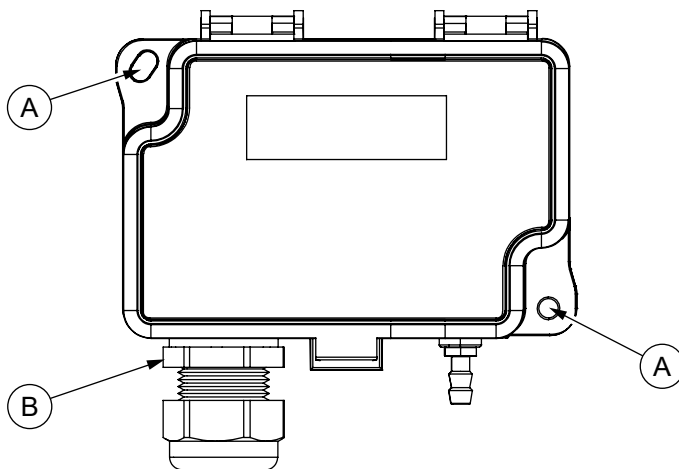

- A. Mounting point
- B. Cable gland

6. Mount the device to the mounting surface with the screws. See the figure below for the correct mounting orientation.

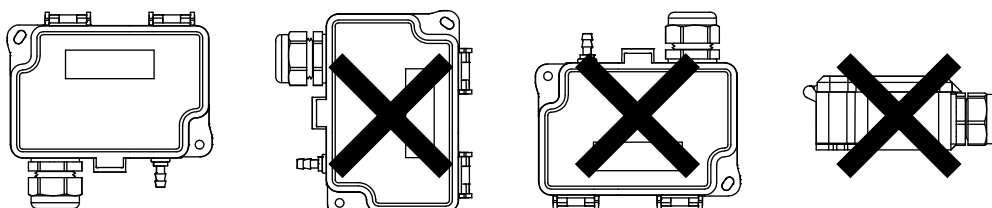

7. Make sure that the device is horizontally and vertically level.

8. Tighten the screws.

## 4.2 Connecting the pressure measurement hoses

Connect the pressure measurement hoses to the pressure connections of the device according to your application:

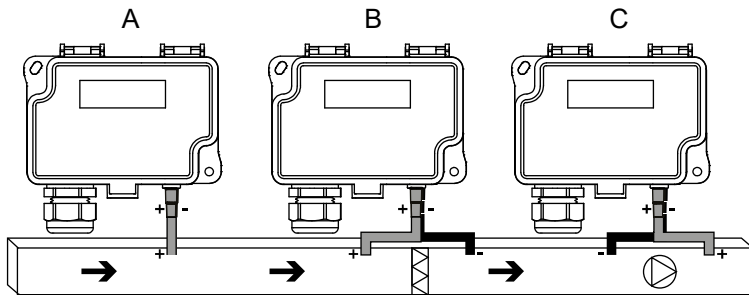

A. Static pressure

B. Filter/damper monitoring

C. Fan/blower monitoring

- If the pressure is static, connect the pressure measurement hose to the "+" connection only.
- Filter or damper monitoring:
  1. Connect a pressure measurement hose to the duct on the high pressure side before the filter/damper and another pressure measurement hose on the low pressure side after the filter/damper.
  2. Connect the high pressure measurement hose to the "+" connection.
  3. Connect the low pressure measurement hose to the "-" connection.
- Fan or blower monitoring:
  1. Connect a pressure measurement hose to the duct on the low pressure side before the fan/blower and another pressure measurement hose on the high pressure side after the fan/blower.
  2. Connect the high pressure measurement hose to the "+" connection.
  3. Connect the low pressure measurement hose to the "-" connection.
- Install the measuring hoses carefully and make sure that the hoses do not bend too tightly. Too tight curves can prevent the air flow to the sensor.

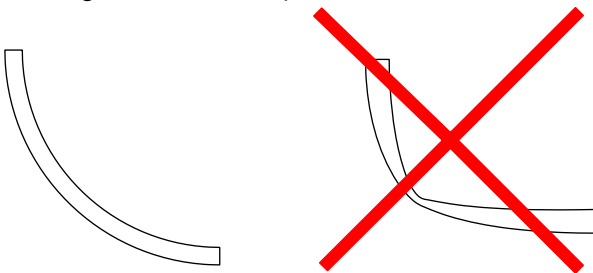

## 4.3 Wiring

- ⚠ WARNING:** Device wiring and commissioning can only be carried out by qualified professionals. Always make the device wirings in de-energised electricity network.
- ⚠ WARNING:** This product is appliance class III product according to IEC 60664-1. The product may only be connected to SELV (separated extra low voltage) electricity network.
- ⚠ WARNING:** The relay port is not protected internally against overload. The wiring of the relay port must be either protected with an external fuse with maximum current rating of 1 A slow blow or the power consumption of the connected external circuitry must be inherently limited to less than 15 W in both normal operation and failure condition.
- ⚠ WARNING:** The relay port may be connected only to SELV (separated extra low voltage) circuitry.

**! CAUTION:** Use single stranded wires or use wire end sleeves if multi stranded wires are used.

**! Important:** For CE and UKCA compliance, a properly grounded shielding cable is required.

1. Open the cover.
2. Unscrew the strain relief on the cable gland.
3. Route the cables for power input, measurement signal output, and relay outputs through the strain relief and the cable gland.
4. Connect the wires to the terminal block according to the table below.

Insert a small flat-head screwdriver into the top slot of the spring-loaded terminal and push gently to open the terminal.

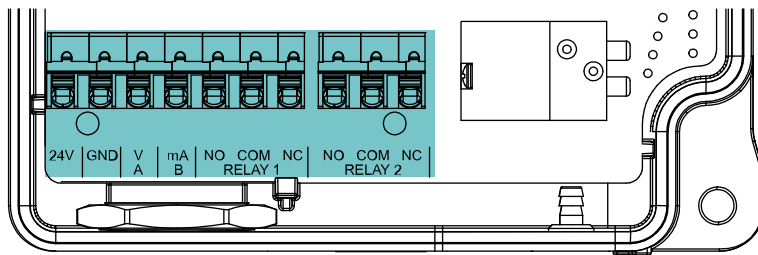

24V	24 Vac/dc
GND	0 V
V	Voltage output (V)
mA	Current output (mA)
NO	Relay 1 output: 30 Vdc, 6 A
COM	
NC	
NO	Relay 2 output (-2R models): 30 Vdc, 6 A
COM	
NC	

5. Tighten the strain relief.

## 4.4 Configuring settings via device menu

Default values are marked with an asterisk (\*) to the menu structure chart below.

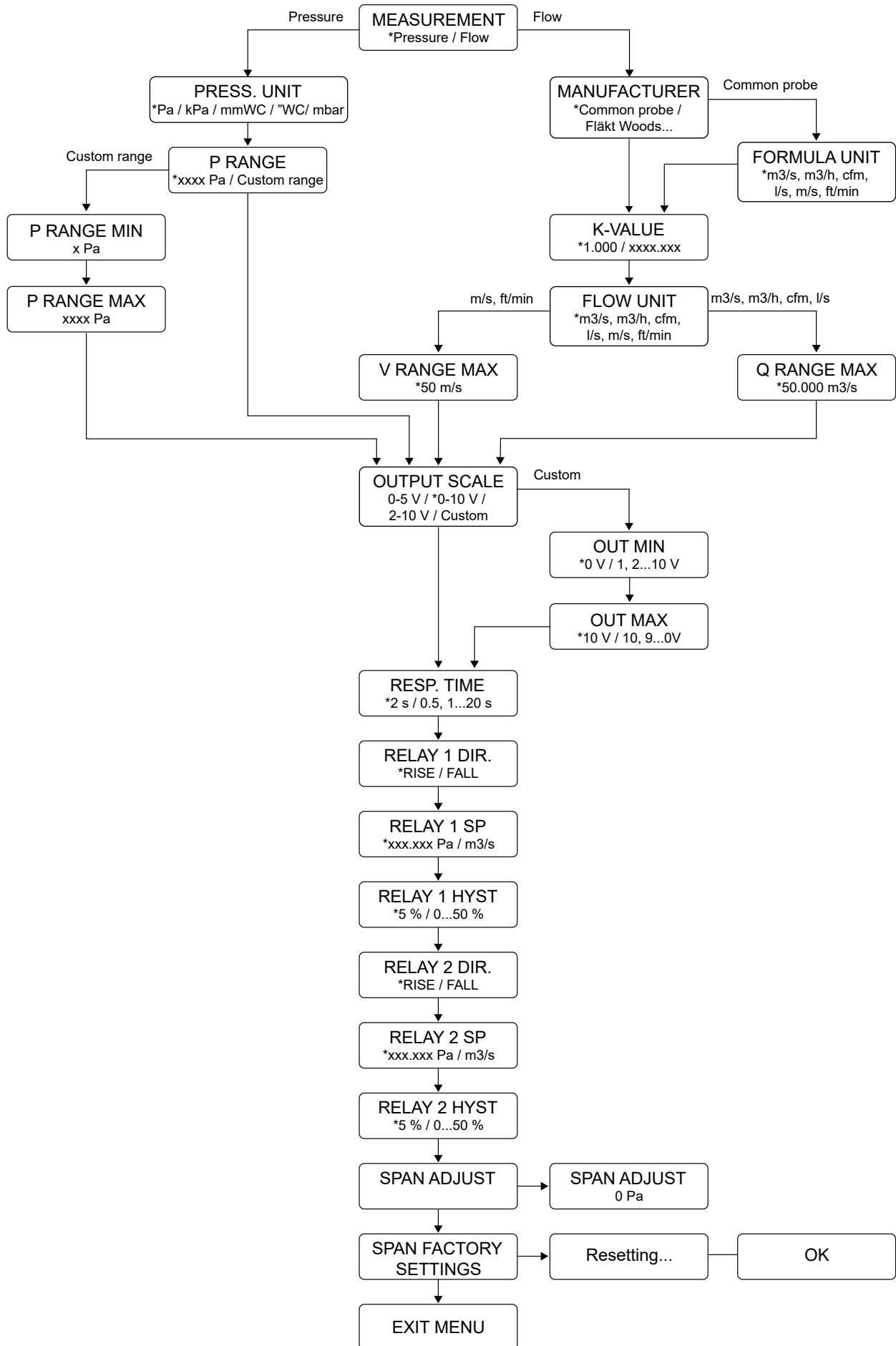

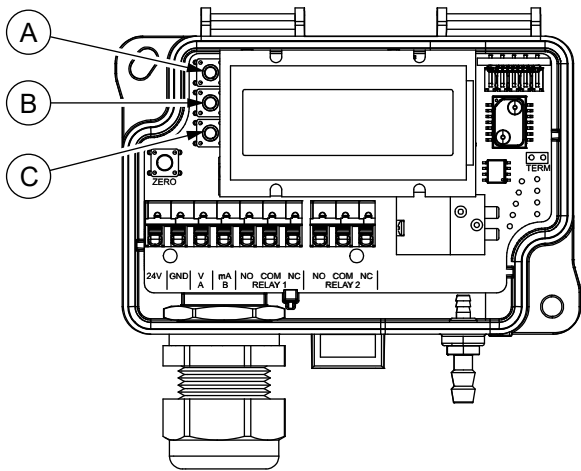

- A. *SELECT* button
- B. *UP* button
- C. *DOWN* button

1. Open the cover.
2. Make sure that the wires are correctly connected.
3. Switch the power on.



**CAUTION:** When the power supply is connected, be extra careful when handling the product without the cover.

4. Press the *SELECT* button for two seconds to activate the device menu.
5. Use the *UP* and *DOWN* buttons to navigate the menu.
6. Press the *SELECT* button to change the value of a menu item.
7. Press the *UP* and *DOWN* buttons to select a value.
8. Press the *SELECT* button to accept the setting and to return to menu navigation.
9. Navigate to the *EXIT MENU* view and press the *SELECT* button to save the settings and exit the menu.

### 4.4.1 Pressure measurement settings

See the subchapters below for the available settings for the menu items shown in the figure.

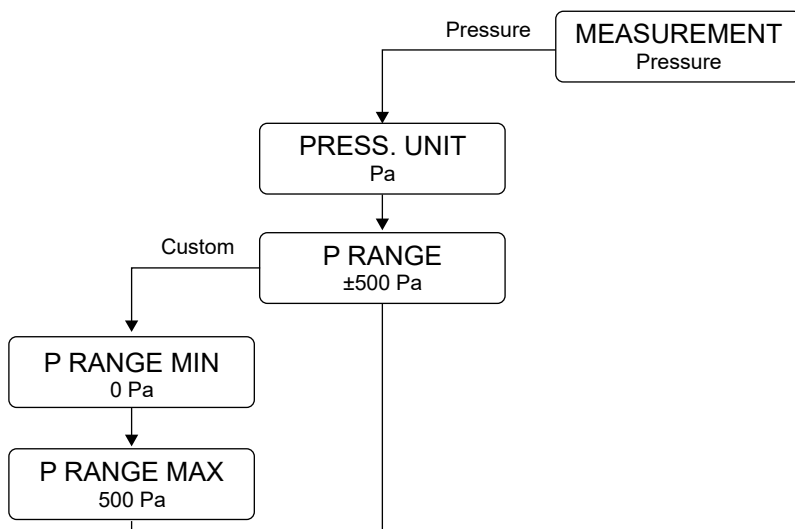

### 4.4.1.1 Press. unit menu

You can select the pressure unit for the device display and the pressure output signal in the *PRESS. UNIT* menu.

The following units are available:

- Pa
- kPa
- mmWC
- "WC
- mbar

The default value is Pa.

### 4.4.1.2 P range menu

You can select the pressure measurement range in the *P RANGE* menu.

Select one of the standard pressure measurement ranges or *Custom range*. If you select *Custom range*, you can set the minimum and maximum pressure measurement ranges in the menus that follow.

#### P range min menu

Select the minimum pressure measurement range.

#### P range max menu

Select the maximum pressure measurement range.

## 4.4.2 Flow measurement settings

See the subchapters below for the available settings for the menu items shown in the figure.

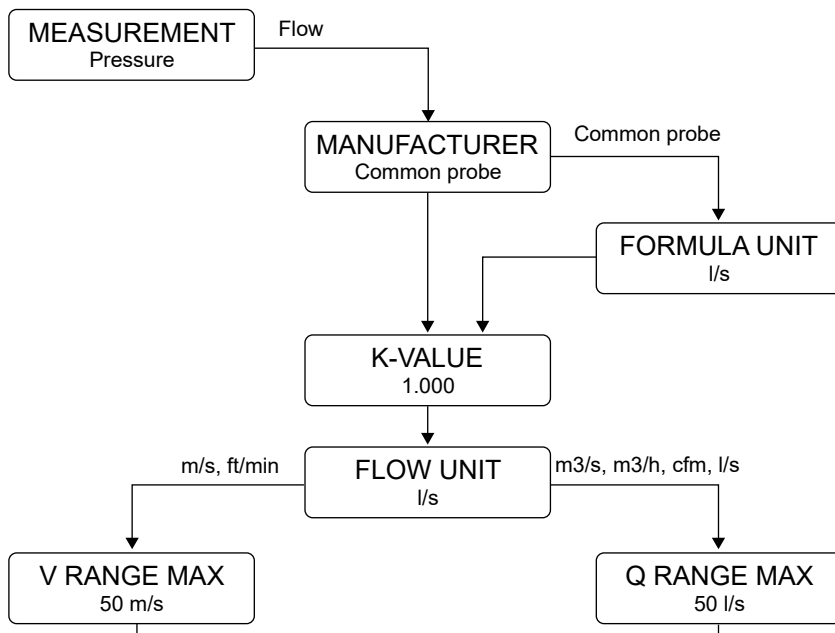

### 4.4.2.1 Manufacturer menu

Select the manufacturer in the *MANUFACTURER* menu if you connect DPI-24 to a fan with pressure measurement points. Select *Common probe* if you use DPI-24 with *PP-PK*, *FloXact™* or other common measurement probe.

If you select *Common probe*, select the measurement unit used in the formula from the *FORMULA UNIT* menu.

Menu selection	Calculation equation	Description
Fläkt Woods	$q = \frac{1}{k} \sqrt{\Delta P}$	Select the fan manufacturer if you connect the device to a fan with pressure measurement points.
Rosenberg	$q = k \sqrt{\frac{2\Delta P}{\rho}}$	
Nicotra-Gebh	$q = k \sqrt{\frac{2\Delta P}{\rho}}$	
Comefri	$q = k \sqrt{\frac{2\Delta P}{\rho}}$	
Ziehl	$q = k \sqrt{\Delta P}$	
Ebm-Papst	$q = k \sqrt{\Delta P}$	
Gebhardt	$q = k \sqrt{\frac{2\Delta P}{\rho}}$	
Nicotra	$q = k \sqrt{\Delta P}$	
Common probe	$q = k \sqrt{\Delta P}$	Select <i>Common probe</i> if you connect the device to a common measurement probe (e.g. PP-PK, FloXact™).

#### 4.4.2.2 Formula unit menu

The *FORMULA UNIT* menu is available if you selected *Common probe* in the *MANUFACTURER* menu. The measurement unit you select in this menu is used in the calculation formula.

The following units are available:

- m<sup>3</sup>/s
- m<sup>3</sup>/h
- cfm
- l/s
- m/s
- ft/min

The correct formula unit depends on the probe you use. For example, if you use the *PP-PK* or *FloXact™* air flow probe, the correct formula unit is l/s.

#### 4.4.2.3 K-value menu

Each fan and measuring probe has a specific K-value. You can select the K-value in the *K-VALUE* menu. See the manufacturer specification for the correct value. The available value range is 0.001...9999.999.

See the following table for the equations used in the flow calculations and the typical K-values according to the fan manufacturer.

Manufacturer menu selection	Equation	Equation unit	Typical K-value range
Fläkt Woods	$q = \frac{1}{k} \sqrt{\Delta P}$	m <sup>3</sup> /s	0.3...99
Rosenberg	$q = k \sqrt{\frac{2\Delta P}{\rho}}$	m <sup>3</sup> /h	37...800

Manufacturer menu selection	Equation	Equation unit	Typical K-value range
Nicotra-Gebh	$q = k\sqrt{\frac{2\Delta P}{\rho}}$	m <sup>3</sup> /h	50...4700
Comefri	$q = k\sqrt{\frac{2\Delta P}{\rho}}$	m <sup>3</sup> /h	10...2000
Ziehl	$q = k\sqrt{\Delta P}$	m <sup>3</sup> /h	10...1500
Ebm-Papst	$q = k\sqrt{\Delta P}$	m <sup>3</sup> /h	10...1500
Gebhardt	$q = k\sqrt{\frac{2\Delta P}{\rho}}$	m <sup>3</sup> /h	50...4700
Nicotra	$q = k\sqrt{\Delta P}$	m <sup>3</sup> /h	50...5300
Common probe	$q = k\sqrt{\Delta P}$	Selectable, m <sup>3</sup> /h as a default	0.001...9999.000

- q*      aif flow
- k*      K-value
- $\Delta P$     differential pressure
- $\rho$       air density

#### 4.4.2.4 Flow unit menu

You can select the flow unit for the device display and the flow output signal in the *FLOW UNIT* menu. Select the same unit you selected in the *FORMULA UNIT* menu.

#### 4.4.2.5 V range max menu

This menu is available if you selected *m/s* or *ft/min* in the *FLOW UNIT* menu.

If you selected *m/s*, you can select the maximum air velocity range between 1.0 m/s and 100.0 m/s. The default value is 100.0 m/s.

If you selected *ft/min*, you can select the maximum air velocity range between 200 ft/min and 20000 ft/min. The default value is 20000 ft/min.

#### 4.4.2.6 Q range max menu

This menu is available if you selected *m<sup>3</sup>/s*, *m<sup>3</sup>/h*, *cfm* or *l/s* in the *FLOW UNIT* menu.

Select the maximum range for air quantity in the *Q RANGE MAX* menu.

### 4.4.3 Output scale menu

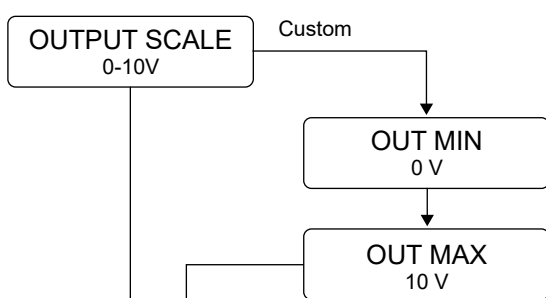

You can select the voltage output scale in the *OUTPUT SCALE* menu.

The following values are available:

- 0-5 V
- 0-10 V (default)
- 2-10 V
- Custom

If you select *Custom*, you can select the minimum and maximum values for the voltage output scale.

#### 4.4.3.1 Out min menu

This menu is available if you selected *Custom* in the *OUTPUT SCALE* menu.

You can select the minimum value for output scale between 0 and 10 V. You can adjust the value by 1 V steps. The default value is 0 V.

You can select a minimum value that is bigger than the maximum value to reverse the operating direction.

#### 4.4.3.2 Out max menu

This menu is available if you selected *Custom* in the *OUTPUT SCALE* menu.

You can select the maximum value for output scale between 0 and 10 V. You can adjust the value by 1 V steps. The default value is 10 V.

You can select a maximum value that is smaller than the minimum value to reverse the operating direction.

#### 4.4.4 Resp. time menu

You can set the measurement response time in the *RESP. TIME* menu. The available values are 0.5, 1, 2...20 s. The default value is 2 s.

#### 4.4.5 Relay output settings

See the subchapters below for the available settings for the menu items shown in the figure.

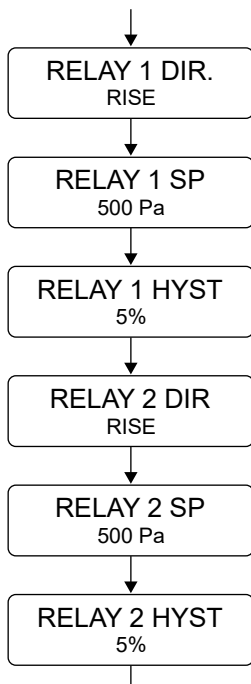

#### 4.4.5.1 Relay 1/2 dir menu

The relay operating direction defines if the relay switches on or off when the pressure or the flow is more than the setpoint value.

You can select the relay operating direction in the *RELAY 1 DIR.* menu for relay 1. If the device has two relay outputs (-2R models), you can select the operating direction of the second relay in the *RELAY 2 DIR.* menu.

The available values are *Rise* and *Fall*. If you select *Rise*, the relay switches on when the pressure or flow goes above the setpoint value. If you select *Fall*, the relay switches off when the pressure or flow goes above the setpoint value. The default value is *Rise*.

#### 4.4.5.2 Relay 1/2 SP menu

You can select the pressure or flow measurement setpoint for relay 1 in the *RELAY 1 SP* menu and for relay 2 in the *RELAY 2 SP* menu, if the device has two relay outputs (-2R models). The available setpoints depend on the device model.

#### 4.4.5.3 Relay 1/2 hyst menu

This setting defines how much the pressure or air flow must drop below the setpoint before the relay switches off if *Rise* is selected in the *RELAY 1/2 DIR* menu. The function is opposite if *Fall* is selected in the *RELAY 1/2 DIR* menu.

You can set the hysteresis value for relay 1 in the *RELAY 1 HYST* menu and for relay 2 in the *RELAY 2 HYST* menu, if the device has two relay outputs (-2R models).

The available values are between 0 % and 50 %. You can adjust the value by 1 % steps. The default value is 5 %.

#### 4.4.6 Span adjust menu

The span point adjustment function is available for devices that have a display. You can use the span point adjustment function to adjust the upper end of the measurement range. Span adjustment may be necessary for devices that are calibrated yearly. You need an accurate, certified pressure calibrator to supply reference pressure to the device during span point adjustment.

If you selected *Flow* in the *MEASUREMENT* menu, the span adjustment value is shown in Pascals. For pressure, the span adjustment value is shown in the selected measurement unit.

Do the steps below to adjust the span point.

1. If the device is not an -AZ model, reset the zero point before you adjust the span point.  
See section [Manual zeroing](#) on page 23 for the instructions.
2. Supply reference pressure to the device.  
The reference pressure should be as close to the maximum measurement range as possible.
3. Select *SPAN ADJUST* in the device menu.  
The measured pressure is shown on the display.
4. Use the *UP* and *DOWN* buttons to adjust the pressure until it matches the reference pressure.
  -  **Note:** The selected response time affects how quickly the adjustment is shown on the display.
5. Confirm span adjustment by pressing the *SELECT* button again.

#### 4.4.7 Span factory settings menu

If you want to reset the span value to factory settings, navigate to the *SPAN FACTORY SETTINGS* menu and press the *SELECT* button. The device starts to reset the span immediately. Wait until the *OK* message is shown on the display.

### 4.4.8 The Exit menu view

Navigate to the *EXIT MENU* view and press the *SELECT* button to save the settings and exit the menu.

## 4.5 Configuring settings using MyTool® application

You can configure the settings of the -BT models with MyTool® application installed in your smartphone. You can download the MyTool® application for Android from Google Play. To configure the device, you first need to connect it to the MyTool® application. When the device is connected to the application, you can make changes to the configuration.

**!** **Note:** You need a MyTool Connect dongle for connecting MyTool® to the device.

**!** **Note:** Exit the device menu before you start to configure the device with the MyTool® application.

1. Open the device cover.
2. Make sure that the wires are correctly connected.
3. Switch the power on.

**!** **CAUTION:** When the power supply is connected, be extra careful when handling the product without the cover.

**!** **Note:** You can also power the device by connecting a USB cable to the MyTool Connect dongle.

4. Insert the MyTool Connect dongle into the connector on the device circuit board. Make sure that the Proidual logo on the dongle points to the pressure connection.

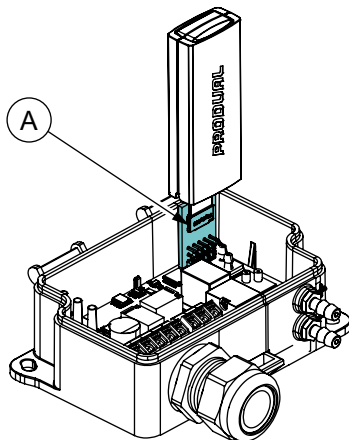

A. Connector for MyTool Connect dongle

The indicator light in the MyTool Connect dongle flashes when the device is ready to connect to a smartphone.

5. Start the MyTool® application.
6. Tap the *Bluetooth Devices* button.

The device list shows the devices that have Bluetooth activated.

7. Tap a device on the list to select it.

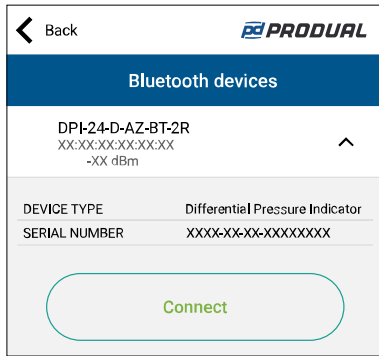

8. Tap the *Connect* button.

The indicator light in the MyTool Connect dongle is on continuously when the device is connected to the MyTool® application.

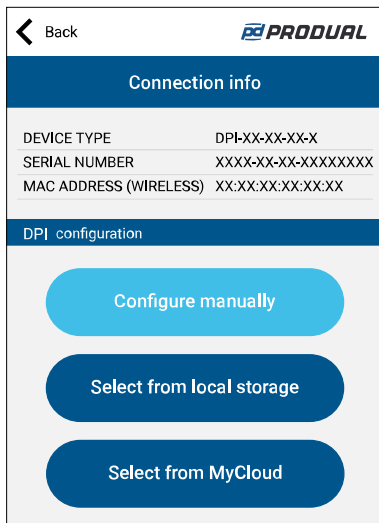

9. Tap the *Configure manually* button.

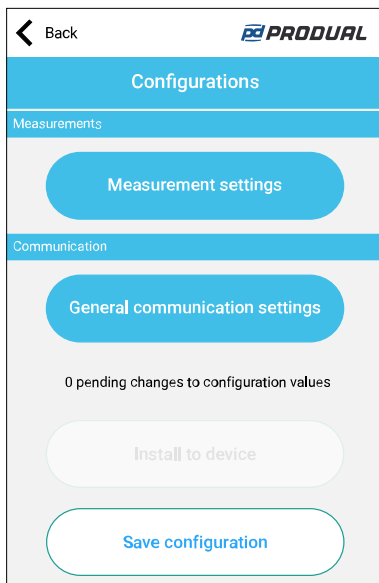

The **Configurations** page has the following menus:

- Measurement settings*    Set up pressure or flow measurement settings and relay settings.
- General communication settings*    Set up communication parameters.

10. Make the changes to the configuration.  
See sections [Configuring measurement settings](#) on page 18 and [Configuring communication settings](#) on page 20 for detailed instructions.
11. When you have made the necessary changes, tap the *Install to device* button on the **Configurations** page to upload and save the changes to the device.

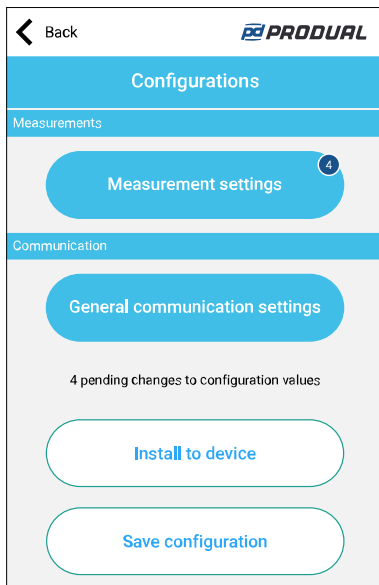

12. Tap the *Back* button to return to the **Connection info** page.
13. Tap the *Disconnect* button to disconnect the device.
14. Remove the MyTool Connect dongle from the device.

### 4.5.1 Configuring measurement settings

On the **Measurement settings** page, you can configure the settings for pressure measurement or flow measurement.

1. Tap the *Measurement settings* button on the **Configurations** page to open the **Measurement settings** page.

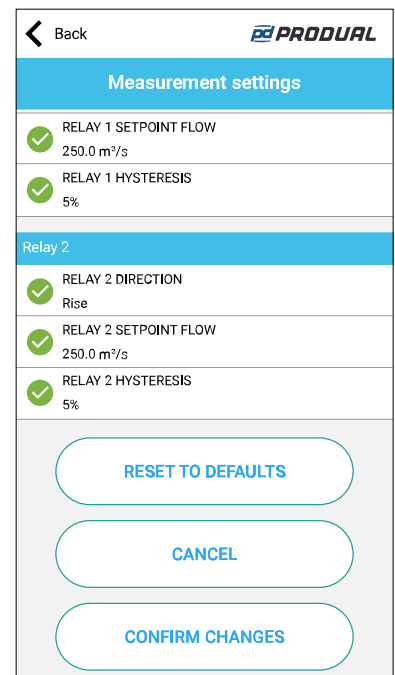
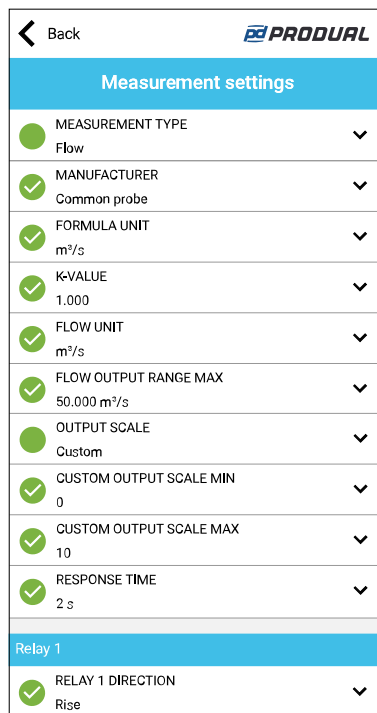
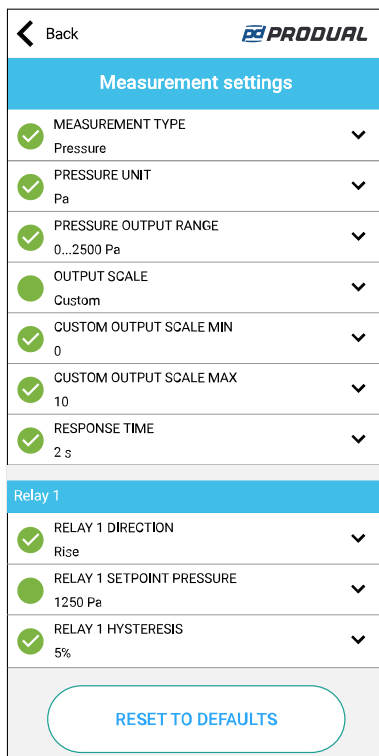

2. Tap a parameter to open the settings for that parameter.
3. Configure the settings.  
See sections [Pressure measurement settings](#) on page 19 and [Flow measurement settings](#) on page 19 below for the available settings.
4. Scroll to the bottom of the page.
5. Tap the *Confirm changes* button to save the changes to the application.
6. On the **Configurations** page, tap the *Install to device* button to upload and save the changes to the device.

#### 4.5.1.1 Pressure measurement settings

Parameter name	Values	Default	Description
Measurement type	Pressure Flow	Pressure	Select <i>Pressure</i> to measure pressure.
Pressure unit	Pa, kPa, mmWC, "WC, mbar	Pa	Select the pressure unit for the device display and the pressure output signal.
Pressure output range			Select one of the standard pressure ranges or <i>Custom selectable</i> . If you select <i>Custom selectable</i> , you can set the minimum and maximum pressure ranges.
Custom pressure output range min		0 Pa	The minimum value for the output range. Shown if you selected <i>Custom selectable</i> in the <i>Pressure output range</i> parameter.
Custom pressure output range max			The maximum value for the output range. Shown if you selected <i>Custom selectable</i> in the <i>Pressure output range</i> parameter.
Output scale	0-5V, 0-10V, 2-10V, Custom	0-10V	Voltage output scale. If you select <i>Custom</i> , you can select the minimum and maximum values for the voltage output scale.
Custom output scale min	0-10	0	Minimum value for the voltage output scale. Shown if you selected <i>Custom</i> in the <i>Output scale</i> parameter.
Custom output scale max	0-10	10	Maximum value for the voltage output scale. Shown if you selected <i>Custom</i> in the <i>Output scale</i> parameter.
Response time	0.5...20 s	2 s	Measurement response time.

#### 4.5.1.2 Flow measurement settings

Parameter name	Values	Default	Description
Measurement type	Pressure Flow	Pressure	Select <i>Flow</i> to measure air flow.
Manufacturer	Common probe, FläktWoods, Rosenberg, Nicotra- Gebhardt, Comefri, Ziehl, ebm-papst, Gebhardt, Nicotra	Common probe	Select the manufacturer in the <i>Manufacturer</i> parameter if you connect DPI-24 to a fan with pressure measurement points. Select <i>Common probe</i> if you use DPI-24 with <i>PP-PK</i> , <i>FloXact™</i> or other common measurement probe.

Parameter name	Values	Default	Description
Formula unit	m <sup>3</sup> /s, m <sup>3</sup> /h, cfm, l/s, m/s, ft/min	m <sup>3</sup> /s	The <i>Formula unit</i> parameter is available if you selected <i>Common probe</i> in the <i>Manufacturer</i> parameter. The measurement unit you select in this menu is used in the calculation formula. The correct formula unit depends on the probe you use. For example, if you use the <i>PP-PK</i> or <i>FloXact™</i> air flow probe, the correct formula unit is <i>l/s</i> .
K-value	0.000...9999.999	1.000	Each fan and measuring probe has a specific K-value. See the manufacturer specification for the correct value. The available value range is 0.001...9999.999.
Flow unit	m <sup>3</sup> /s, m <sup>3</sup> /h, cfm, l/s	m <sup>3</sup> /s	Select the flow unit for the device display and the flow output signal. Select the same unit you selected for the <i>Formula unit</i> parameter.
Flow output range max			In this parameter, you can set the maximum output range for flow measurement.
Output scale	0-5V, 0-10V, 2-10V, Custom	0-10V	Voltage output scale. If you select <i>Custom</i> , you can select the minimum and maximum values for the voltage output scale.
Custom output scale min	0-10	0	Minimum value for the voltage output scale. Shown if you selected <i>Custom</i> in the <i>Output scale</i> parameter. You can select a minimum value that is bigger than the maximum value to reverse the operating direction.
Custom output scale max	0-10	10	Maximum value for the voltage output scale. Shown if you selected <i>Custom</i> in the <i>Output scale</i> parameter. You can select a maximum value that is smaller than the minimum value to reverse the operating direction.
Response time	0.5...20 s	2 s	Measurement response time.

### 4.5.1.3 Relay settings

*Relay 1* section is shown on the **Measurement settings** page for -R models. *Relay 1* and *Relay 2* sections are shown for -2R models. Both relays have the same settings available.

Parameter name	Values	Default	Description
Relay direction	Rise / Fall	Rise	Relay operating direction defines if the relay switches on or off when the pressure/flow is more than the setpoint value. The relay switches on if <i>Rise</i> is selected and measured value is more than the setpoint value. If <i>Fall</i> is selected, the relay switches on when the measured value is less than the setpoint value.
Relay setpoint			Pressure or flow setpoint for the relay.
Relay hysteresis	0...50 %	5%	Relay hysteresis defines how much the measured value must drop below the setpoint before the relay switches off if <i>Rise</i> is selected for the <i>Relay direction</i> parameter. The function is opposite if <i>Fall</i> is selected.

### 4.5.2 Configuring communication settings

On this settings page, you can rename the device.

1. Tap the *General communication settings* button on the **Configurations** page to open the **Communication parameters** page.

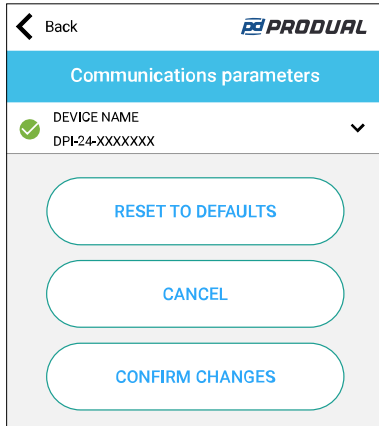

2. Tap the *Device name* field to rename the device.
3. Enter the new name in the field.
4. Tap the *Confirm changes* button to save the changes to the application.
5. On the **Configurations** page, tap the *Install to device* button to upload and save the changes to the device.

Parameter name	Values	Default	Description
Device name	0...32 characters	Unnamed device	Device name. Device name supports ASCII characters. This name is shown on the <b>Bluetooth devices</b> page.

### 4.5.3 Saving and loading the configuration

If you have several devices to configure, you can save the configuration and then load it for the next device.

1. After you have configured the settings, tap the *Save configuration* button on the **Configurations** page.

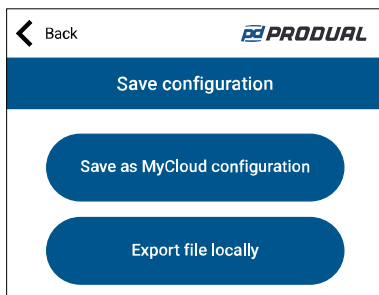

2. On the **Save configuration** page, select *Save as MyCloud configuration* to save the configuration to service or *Export file locally* to save the configuration to your smartphone or other mobile device you are currently using.
3. Tap the *Configuration name* field and enter a name for the configuration.
4. Tap the *Save* button to save the configuration.
5. Tap the *Install to device* button to save the changes to the device if there are pending changes.
6. Tap the *Back* button to return to the **Connection info** page.
7. Tap the *Disconnect* button to disconnect the device.
8. Remove the MyTool Connect dongle from the device.

9. Insert the MyTool Connect dongle into the next device and connect it to the MyTool® application.
10. On the **Connection info** page, tap the *Select from local storage* button if you saved the configuration to your smartphone or the *Select from MyCloud* button if you saved the configuration to the cloud.
11. Tap the configuration file to select it.

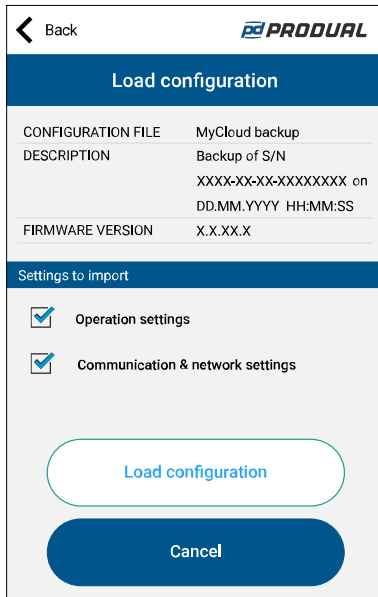

12. Select the settings you want to import.
13. Tap the **Load configuration** button to load the configuration. You can make changes to the loaded configuration, if necessary.
14. When you have made the necessary changes, tap the *Install to device* button on the **Configurations** page to upload and save the changes to the device.

#### 4.5.4 Resetting device settings to defaults

Do the steps below to reset the device settings to the default values.

1. Tap the *Measurement settings* button on the **Configurations** page to open the **Measurement settings** page.
2. Scroll to the bottom of the page.
3. Tap the *Reset to defaults* button.
4. Tap the *Confirm changes* button to save the changes to the application.
5. On the **Configurations** page, tap the *Install to device* button to upload and save the changes to the device.

## 5 Maintenance

### 5.1 Automatic zeroing

The -AZ models include an automatic zeroing function, which adjusts the transmitter zero point every 10 minutes. Automatic zeroing removes output signal drift that can occur due to thermal, electronic or mechanical effects. As a result, it is not necessary to calibrate the transmitter zero point manually.

The zeroing takes approximately 4 seconds. During the zeroing process, the output and display values are locked to the latest measured value to avoid conflict with the building management system. A red LED comes on when zeroing starts. When the zeroing process is completed, the device returns to its normal measuring mode.

### 5.2 Manual zeroing

You can eliminate zero point drifting by using the zeroing button on the circuit board. Manual zeroing is not necessary for the -AZ models.

**!** **Note:** Supply voltage must be connected to the device at least 30 minutes before zeroing.

1. Disconnect both pressure measurement hoses from the device.
2. Push the zeroing button until text *Zeroing...* appears on the display.  
A red LED comes on when zeroing starts.

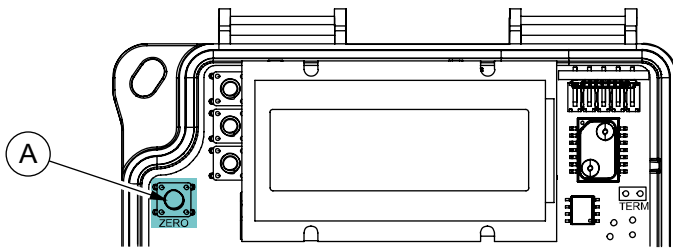

A. Zeroing button

3. Wait until the *Zeroing...* text disappears from the display.
4. Connect the pressure measurement hoses. See section [Connecting the pressure measurement hoses](#) on page 7.

## 6 Disposal

This device is considered as electrical and electronic equipment for disposal in terms of the applicable European Directive. At the end of life, the product must enter the recycling system at an appropriate collection point.

- The device must be disposed through channels provided for this purpose.
- The disposal must be completed according to the local and currently applicable laws and regulations.

Generally all metals can be recycled as material. Plastics and cardboard packaging material can be used in energy recovery. Printed circuit boards need selective treatment according to IEC 62635 guidelines. To aid recycling, plastic parts are marked with an appropriate identification code. Contact your local Produal distributor for further information on environmental aspects and recycling instructions for professional recyclers.

